

0.3mm Pitch FPC Connector, ZIF R/A SMT Type

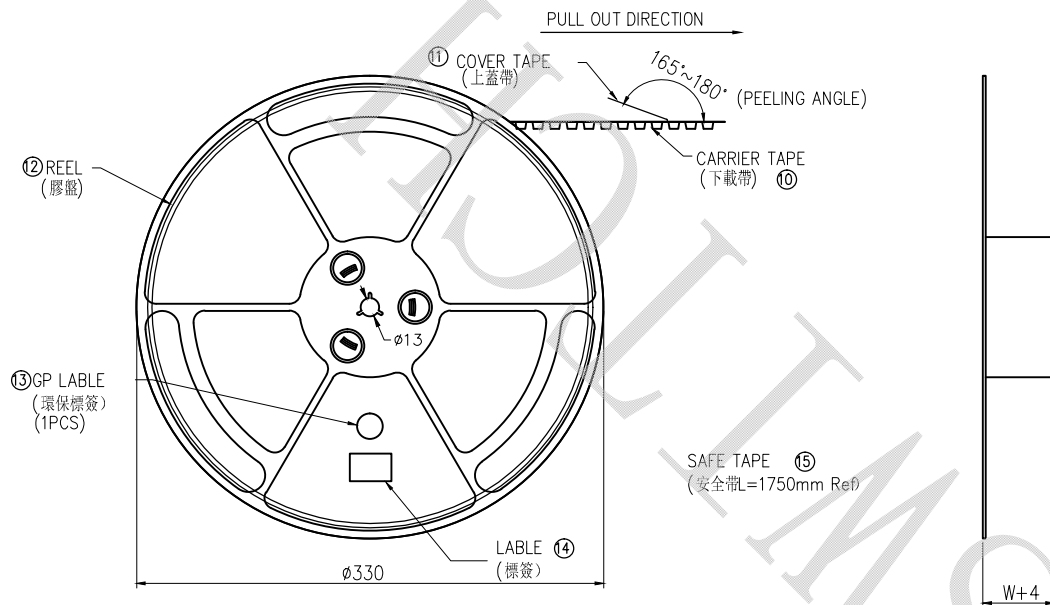

SCALE 1: 4

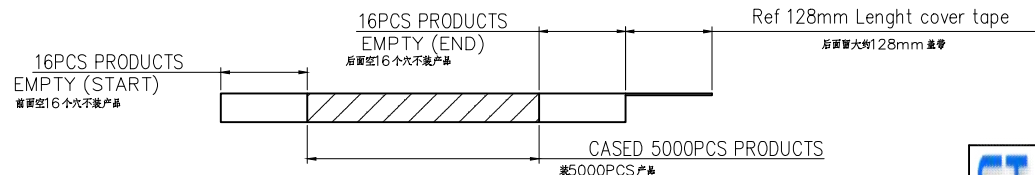
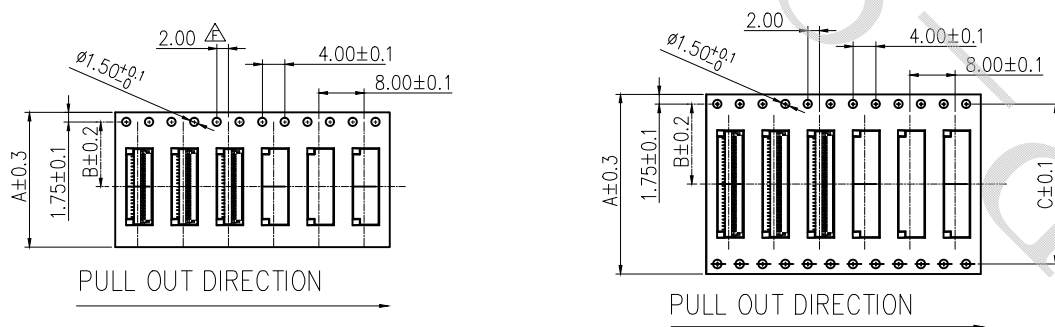

NOTE:

- 1.10 Sprocket hole pitch cumulative tolerance ± 0.20 .
2. Carrier camber is within 1mm in 100mm.
3. Material: black conductive polystyrene alloy.
4. Material Thickness: 0.3 ± 0.05 mm.
5. All dimensions meet EIA-481-B requirements.
6. 5000pcs Pef Reel.
7. For tape width(dim W)16 and 24mm pilot holes are provided on one sides. For tape width(dim W)32, 44 and 56mm pilot holes are provided on both sides.

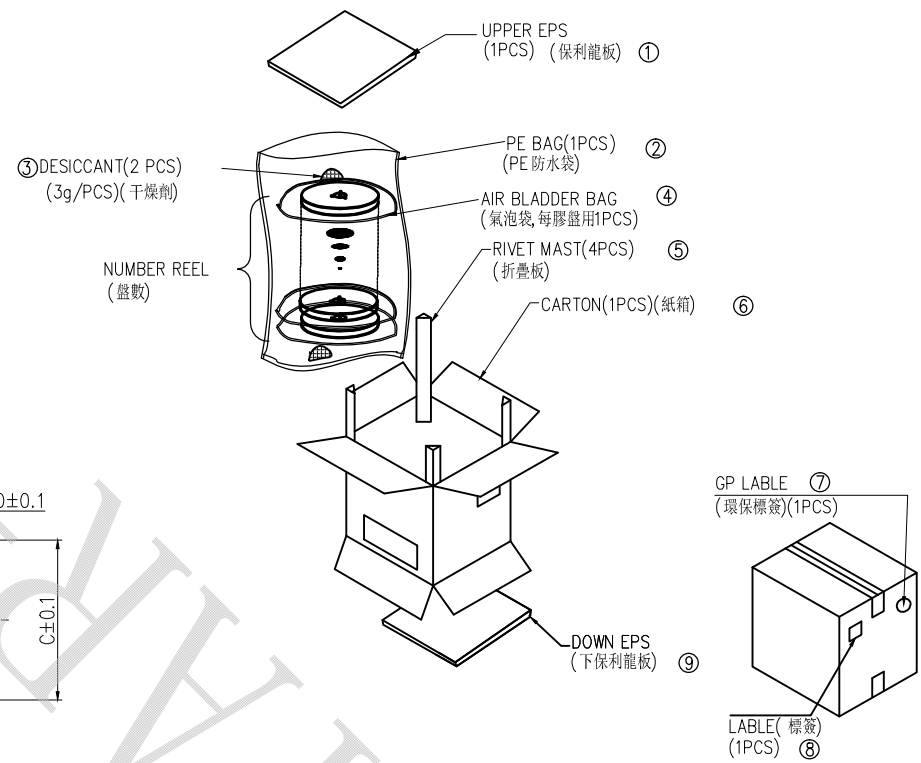

PIN NO.	W	A	B	C	PCS /REEL	REEL/CARTON	SUM(PCS)
13PIN~25PIN	20.5	16	7.50	-	5000	13	65000
27PIN~49PIN	28.5	24	11.5	-	5000	10	50000
51PIN~61PIN	36.5	32	14.2	28.4	5000	8	40000
67~73PIN	48.5	44	20.2	40.4	5000	6	30000

STAR-SWITCH 深圳市恒星兴电子有限公司
Shenzhen Star Electronic Co., Ltd

-TOLERANCES- UNLESS OTHERWISE SPECIFIED 公差參考表		Drawing: heyichen	PART NAME: ZIF连接器	
X.X : ±0.30	X.X* : ±5°	Checked: hanyu	PART NO: HXX-F0310-XX10-1-2	
X.XX : ±0.20	X.XX* : ±2°	Approved: luojun	REV. A	UNII: MM
X.XXX : ±0.10	X.XXX* : ±1°	Date: 2020.8.18	SHEET: 1/1	
Model NO: HXX-3001				